

Current-Insulated Bearings Prevent Damage Caused by Electrical Current

Technical Product Information

Damage Caused by Electrical Current and Its Consequences · Current-Insulated Bearings as a Preventive Measure

Damage Caused by Electrical Current and Its Consequences

Rolling bearings used in:

- wheelsets and traction motors (rail vehicles)
- DC and AC motors (drivetrains)
- generators (wind power)

can be exposed to electrical current. In a worst-case scenario, this can damage raceways and rolling elements, which, in turn, causes the motor or generator to fail prematurely and without warning. On top of the extra expenses incurred for repairs, this also means additional costs caused by machine downtime and the resulting production losses.

A much more economical solution is to provide for the use of current-insulated bearings during the planning stage. This reduces maintenance and repair costs, and increases machine availability – all of which means greater value for the customer.

In most cases, it is sufficient to interrupt the electric circuit between the housing and shaft, in order to mount current-insulated bearings at one or both bearing locations, depending on the application.

Generally, current-insulated bearings (ceramic-coated or hybrid) exhibit significantly higher resistance to electrical current than standard bearings.



Current-Insulated Bearings as a Preventive Measure

As a rule, it is very difficult to eliminate the causes of bearing **voltages** that are induced by the motor. Nevertheless, it is possible to avoid damage to the bearing, if the **flow of current** can either be prevented or at least significantly reduced. Many types of current-insulated rolling bearings are available today for this very purpose. Which components need to be insulated depends on the type of voltage involved:

Induced Voltage along the Shaft

This produces a circular current, which is closed via bearing 1, the housing, and bearing 2. Such shaft voltages are often the result of an asymmetrical distribution of the magnetic flux within the motor. This is especially evident in motors with only a few pairs of poles. If this is the case, it is sufficient to disrupt the flow of current by insulating one of the two bearings.

Voltage between the Shaft and the Housing

In this case, electrical currents flow through each of the two bearings in the same direction. The most likely cause is the converters' common-mode voltage. This type of a situation might require insulating both bearings.

Which type of electrical insulation is to be used depends on the time response of the given voltages. With **DC voltage** and low-frequency AC voltage, the choice depends on

Current-Insulated Bearings as a Preventive Measure · Typical Damage Caused by Electrical Current Passing through the Bearing

the **ohmic resistance** of the bearing. With higher-frequency AC voltage (often encountered in converters!), it depends on the capacitive reactance of the bearing. Basically, a current-insulated bearing acts like a resistor and capacitor connected in parallel. To ensure good insulation, the ohmic resistance should be as high as possible, and the capacitance should be as low as possible.

Typical Damage Caused by Electrical Current Passing through the Bearing

Regardless of whether a bearing was exposed to direct current or alternating current (up to frequencies in the MHz range), the resulting changes to the surface are always the same: Uniformly dull, gray marks in the raceways (Fig. 1) and on the rolling elements. These marks are not very specific and can also be caused by other factors (e. g. lubricating oil containing abrasives).

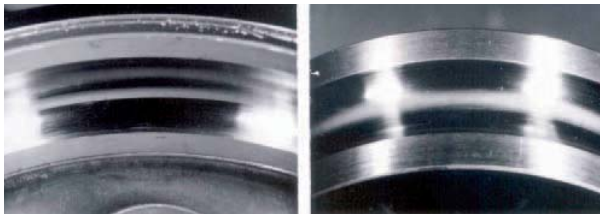

1: Dull and Gray Marks
left raceway outer ring, right raceway inner ring

“Fluting” refers to the washboard patterns that develop along the raceway surface in the direction of rotation (Fig. 2). This type of damage usual indicates that electrical current has passed through the bearing.

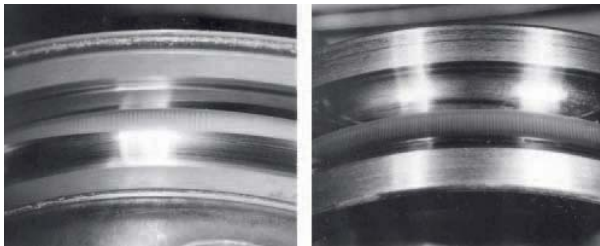

2: Fluting
left raceway outer ring, right raceway inner ring

An examination under a scanning electron microscope (SEM) reveals that the damage shown in figures 1 and 2 is characterized by densely-packed craters (caused by localized melting) and welding beads with micrometer-sized diameters covering the raceways. This definitively proves that electrical current has passed through the bearing.

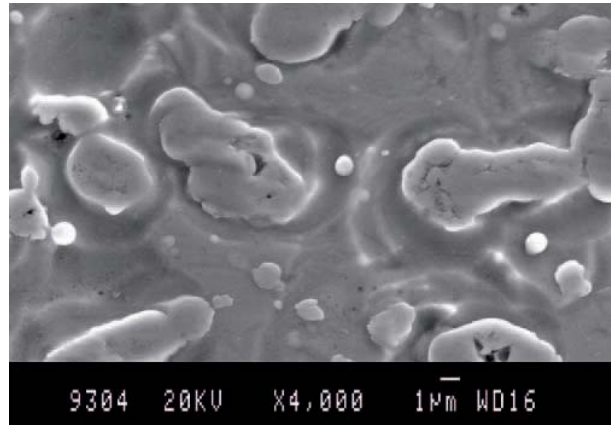

3: SEM micrograph of the Damage Structure

These **craters** and **welding beads** are the result of electrical discharges between the microscopic peaks that are always found in raceways and on rolling-element surfaces. When a spark penetrates a fully-developed lubricating film at a bottleneck, it causes the adjacent surfaces to momentarily melt. In the mixed-friction range (metal-to-metal contact), the affected surfaces are temporarily fused together, then immediately broken apart again by the rotation of the bearing. In both cases, material also separates from the surfaces, where it immediately solidifies to form welding beads. Some of these beads get mixed in with the lubricant, the rest are deposited on the metal surfaces. Craters and welding beads can be flattened and smoothed as the rolling elements continue to pass over them. If there is a continuous flow of current, the (thin) surface layers, over time, repeat this melting and solidifying process over and over again.

Most bearing failures, however, are caused by **fluting** (Fig. 2). These washboard patterns in raceways and on rollers form as a result of the combined effects of a continuous flow of electrical current and the vibrational

Typical Damage Caused by Electrical Current Passing through the Bearing · Ceramic-Coated Bearings

properties of the bearing components. Each time the rolling element comes into contact with a sufficiently-large crater, it becomes radially displaced; the extent of the element's displacement depends on the bearing's internal geometry and speed, as well as on the loads acting on the bearing. As the rolling element swings back, the thickness of the lubricating film is eroded, resulting in more sparkovers in this area – a self-sustaining process has been triggered. After a while, the entire circumference of the ring's raceway can become covered with fluting damage. This causes more pronounced bearing vibrations, finally leading to bearing failure.

Calculated current density – i.e., the effective amperage divided by the total area of contact between the rolling elements and the bearing's inner ring and outer ring (which is dependent on the type of bearing and on the operating conditions) – has proven itself in the field as a reliable criterion for assessing the level of danger posed by electrical current. When current densities are less than approx. $0,1 A_{eff}/mm^2$, there is no risk of fluting, according to our present level of understanding. Densities at or above $1 A_{eff}/mm^2$, however, are likely to cause this type of damage.

Effect of Current on Lubricant

Electrical current also **negatively affects the lubricant**, whose base oil and additives oxidize and develop cracks. (This is clearly evident under the infrared spectrum.) The lubricating properties are compromised by premature aging as well as by an increased concentration of iron particles, which can cause the bearing to overheat.

Ceramic-Coated Bearings



4: Ceramic-Coated Deep Groove Ball Bearings

Features and Benefits of Coated FAG Bearings

- Oxide ceramic coatings (**J20...**) provide a high level of insulation. Plasma spraying is used to apply these coatings to the bearing surfaces (Fig. 5).
- Thanks to a special sealant, the **J20AA coating** retains its insulating properties even in a damp environment. The resulting oxide ceramic coating is very hard, wear resistant, and a good thermal conductor.
- The external dimensions of the current-insulated rolling bearings are in accordance with DIN 616 (ISO 15). This means that they are interchangeable with standard bearings.
- For special applications, such as those with a rotating outer ring, we recommend using an inner ring coated with J20C.
- Starting with the 62-series and up, coated deep-groove ball bearings are available in both open and sealed versions (with lip seals on one or both sides). This enables the user to also benefit from the advantages offered by for-life lubrication.

The Coating Process · Electric Resistance

The Coating Process

The plasma spraying process involves generating an arc between two electrodes to ionize a noble gas that is issued from the plasma torch. The resulting plasma jet is used to carry the injected aluminum oxide powder. This powder is melted by the heat and sprayed at high speed onto the outer or inner ring. When applied in this manner, the oxide layer adheres extremely well to the base material. It is then sealed and ground to size.



5: Plasma-Spraying

Electric Resistance

The coatings are subjected to a 100% quality inspection and guarantee a dielectric strength of at least 1000 VDC (J20AA, J20C) or 500 VDC (J20B), respectively.

Below this voltage, the insulating layer permits only extremely low levels of current to flow through the bearing. It offers resistance to DC currents and to AC currents:

DC resistance

At room temperature, the layer typically has a DC resistance of 1–10 GOhm, depending on the bearing size. As the temperature increases, the DC resistance decreases exponentially, typically by approx. 40–50 % per 10 K. But even at operating temperatures of 60 °C or even 80 °C, the insulating layer still has a resistance of several MOhm. According to Ohm's law ($I = U/R$), this means that voltages of up to 1000 V only produce currents that are significantly below 1 mA, which are not critical for bearings.

AC resistance

The insulated unit acts like a capacitor (C) which can accumulate charges. When exposed to an AC voltage, this causes an alternating current to flow through the contact area between the rolling element and raceway. In the case of a harmonic time dependence with angular frequency ω , the rms values for current and voltage are calculated using the formula

$$I = U \cdot \omega \cdot C.$$

Analogous to Ohm's law, $Z = 1/\omega C$ is the capacitive reactance of the bearing. A bearing with an oxide ceramic coating typically has a capacitance of 2–20 nF, depending on the bearing size. So, at a frequency of 50 Hz, it has a capacitive reactance of 0,15–1,5 MOhm, which is significantly lower than its DC resistance. At higher frequencies, this value decreases even further. Still, in most cases it will be significantly **higher than the resistance of a non-insulated bearing**, which, at voltages higher than 1 V, is very low (1 Ohm and less).

Types of Coatings · Range of Sizes

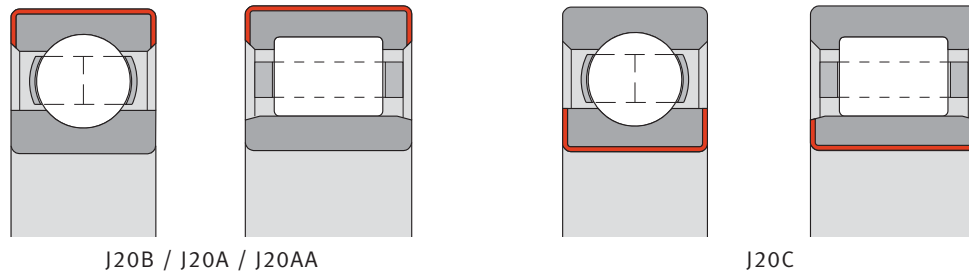

Types of Coatings · Range of Sizes

	J20B	J20A ^{*)}	J20AA	J20C
Disruptive Voltage	500 VDC	1 000 VDC	1 000 VDC	1 000 VDC
Environment	dry	dry	dry/damp	dry/damp
Coating Thickness	<100 µm	>200 µm	≈200 µm	≈200 µm
Applicable	70...1 400 mm	70...1 400 mm	70...500 mm	70...340 mm
Dimensions	outside diameter	outside diameter	outside diameter	inner ring bore

^{*)} Preferably used for bearings with an outside diameter of at least 500 mm.

The surfaces of the rings to be coated must be cylindrical; they must not be interrupted by lubricating holes or grooves.

Bearing Designs with a Ceramic Coating:

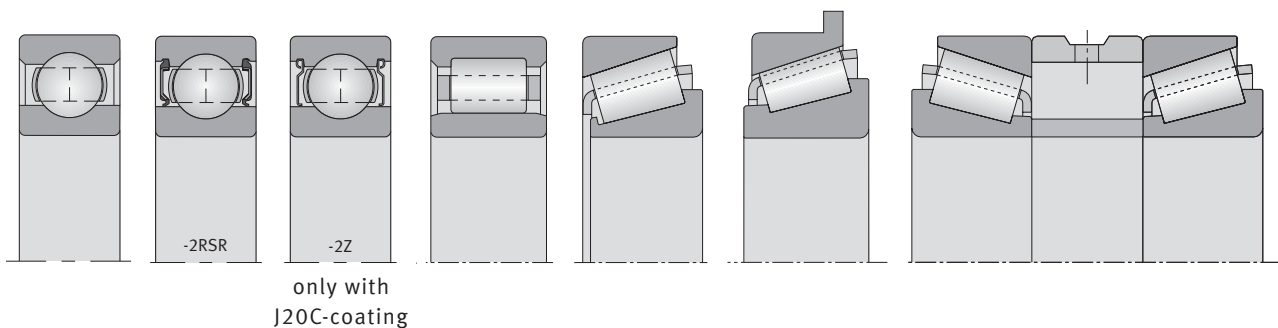

If desired, other bearing designs can be also be coated (upon consulting with the appropriate technical department).

Recommended FAG rolling bearings with a ceramic coating are listed on pages 6–8.

Ordering examples:

6220-2RSR-J20AA-C3 Deep groove ball bearing with a coated outer ring, with seals on both sides and radial clearance C3.

NU214-E-M1-F1-J20B-C4 Cylindrical roller bearings with a coated outer ring and radial clearance C4.

6330-J20C Deep groove ball bearings with a coated inner ring

Ball Bearings with a Ceramic Coating

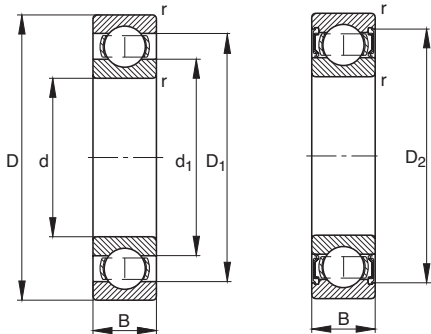

Ball Bearings with a Ceramic Coating d 60–180 mm

Designation	Mass	Dimensions							Load Rating		Fatigue	Limiting	Reference
		d	D	B	r	D ₁	D ₂	d ₁	dyn.	stat.	Limit Load	Speed	Speed
FAG	kg	mm							kN	kN	kN	min ⁻¹	min ⁻¹
6212-M-J20B-C4	0,98	60	110	22	1,5	95,6		76,1	52	36	2,24	14 000	6 800
6213-J20B-C4	1	65	120	23	1,5	103,1		82,3	60	41,5	2,55	13 000	6 300
6313-M-J20AA-C5	2,55	65	140	33	2,1	117,5		88,6	93	60	3,95	11 000	6 400
6214-2RSR-J20AA-C3	1,11	70	125	24	1,5		110,7	86,8	62	44	2,9	12 000	6 100
6215-M-J2B-C4	1,42	75	130	25	1,5	112,8		92,5	65,5	49	3,35	11 000	5 900
6215-M-P6-J20AA-R85-105	1,42	75	130	25	1,5	112,8		92,5	65,5	49	3,35	11 000	5 900
6315-M-J20AA-C3	3,74	75	160	37	2,1	133,2		101,8	114	76,5	4,65	9 500	5 800
6016-M-J20AA	0,997	80	125	22	1,1	111		94	47,5	40	2,34	12 000	6 500
6216-J20AA-C3	1,46	80	140	26	2	121,3		98,8	72	54	3,45	11 000	5 500
6316-J20AA-C3	3,75	80	170	39	2,1	141,8		108,6	122	86,5	5,2	9 000	5 500
6316-M-J20B-C4	4,44	80	170	39	2,1	141,8		108,6	122	86,5	5,2	9 000	5 500
F-808916.6316-J20AA	3,69	80	170	39	2,1	141,8		108,6	122	86,5	5,2	9 000	5 500
6317-M-J20AA-C3	5,05	85	180	41	3	151,6		114,4	132	96,5	5,8	8 000	5 300
6218-J20AA-C3	2,21	90	160	30	2	139,4		112,3	96,5	72	4,2	9 000	5 100
6318-M-J20AA-C3	6,14	90	190	43	3	157,1		123,8	134	102	5,8	8 000	5 100
6319-M-J20AA-C4	7,05	95	200	45	3	166,9		129,1	146	114	6,4	7 500	4 950
6220-J20C-C3	3,3	100	180	34	2,1	154,8		124,7	122	93	5,4	8 000	4 800
6220-M-J20AA-R95-120	3,9	100	180	34	2,1	154,8		124,7	122	93	5,4	8 000	4 800
6320-M-J20AA-C3	8,64	100	215	47	3	179		138,6	163	134	7,4	7 000	4 650
16021-M-J20AA-C5	1,42	105	160	18	1	141,2		124,2	54	54	2,39	9 500	3 950
6322-M-J20AA-C3	11,7	110	240	50	3	197,4		153,4	190	166	8,6	6 300	4 150
6324-M-J20AA-C3	15	120	260	55	3	214,9		165,1	212	190	9	6 000	3 850
6326-M-J20AA-C3	18,3	130	280	58	4	231,2		178,9	228	216	9,8	5 600	3 500
6230-J20AA	10,3	150	270	45	3	229,1		191,6	176	170	7,8	5 600	3 350
6336-M-J20AA-C4	43	180	380	75	4	317		245,2	355	405	16,3	3 800	2 440

Cylindrical Roller Bearings with a Ceramic Coating

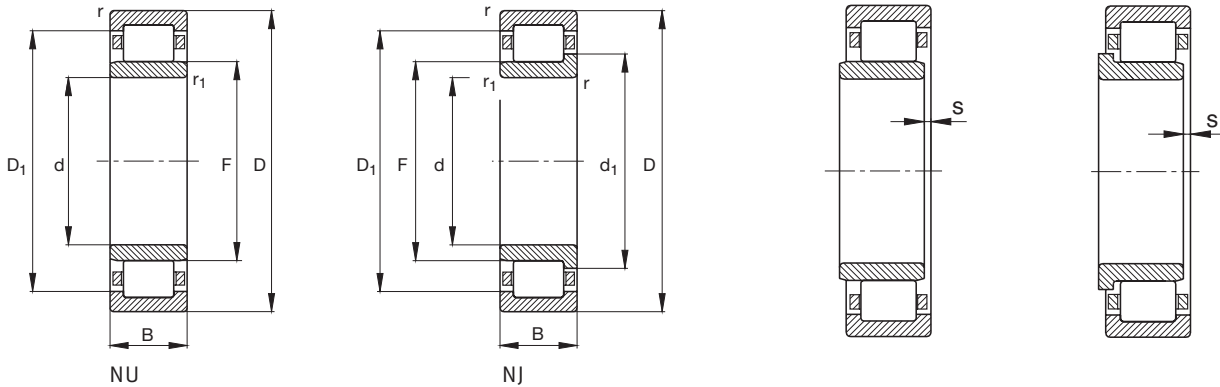

Cylindrical Roller Bearings with a Ceramic Coating d 60–140 mm

Designation	Mass	Dimensions										Load Rating		Fatigue Limit Load	Limiting Speed	Reference Speed
		d	D	B	r	r ₁	s ¹⁾	F	D ₁	d ₁	dyn.	stat.				
FAG	kg	mm			min	min			≈	≈	kN	kN	kN	min ⁻¹	min ⁻¹	
NJ312-E-M1-F1-J20B-C4	2,14	60	130	31	2,1	2,1	1,8	77	109,6	84,4	177	157	26,5	5 000	5 300	
NU214-E-M1-F1-J20B-C4	1,29	70	125	24	1,5	1,5	1,6	83,5	109,4		140	137	19	5 300	4 750	
NU314-E-M1-F1-J20B-C4	3,16	70	150	35	2,1	2,1	1,7	89	126,8		242	222	30	4 500	4 550	
NU215-E-TVP2-J20AA-C3	1,27	75	130	25	1,5	1,5	1,2	88,5	114,4		154	156	21,7	5 300	4 500	
NU215-E-M1-F1-J20B-C4	1,41	75	130	25	1,5	1,5	1,2	88,5	114,4		154	156	21,7	5 300	4 500	
NU216-E-M1-F1-J20B-C4	1,71	80	140	26	2	2	1,3	95,3	122,9		165	167	22,6	4 800	4 250	
NJ316-E-M1-F1-J20B-C4	4,48	80	170	39	2,1	2,1	0,7	101	143,9	110,4	300	275	46	3 800	4 150	
NU218-E-TVP2-J20AA-C3	2,36	90	160	30	2	2	1,5	107	139,7		215	217	28,5	4 300	3 950	
NUP218-E-TVP2-J20AA-C3	2,46	90	160	30	2	2	-	107	139,7	114,3	215	217	35	4 300	3 950	
NJ219-E-TVP2-J20AA	2,94	95	170	32	2,1	2,1	-	112,5	148,6	120,5	260	265	41,5	3 800	3 700	
NU219-E-M1-F1-J20B-C4	3,25	95	170	32	2,1	2,1	0,7	112,5	148,6		260	265	34	3 800	3 700	
NU220-E-TVP2-J20AA-C3	3,49	100	180	34	2,1	2,1	1,5	119	156,9		295	305	38,5	3 800	3 500	
NU320-E-M1-F1-J20AA-C4	8,77	100	215	47	3	3	1,2	127,5	182		450	425	53	3 200	3 400	
NU224-E-TVP2-J20AA-C3	5,8	120	215	40	2,1	2,1	1,4	143,5	187,8		390	415	52	3 200	3 100	
F-809035.NU228-E-J20AA	9,39	140	250	42	3	3	2	169	216,7		460	510	59	4 800	2 600	

¹⁾ axial displacement

Tapered Roller Bearings with a Ceramic Coating

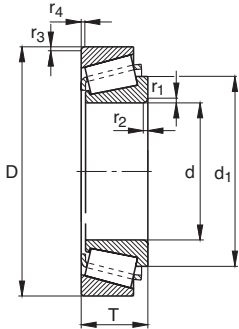

Tapered Roller Bearings with a Ceramic Coating d 89,945–254 mm

Designation	Mass m kg	Dimensions						Load Rating		Fatigue Limit Load	Limiting Speed
		d mm	D	T/2B ¹⁾	r _{1,2} min	r _{3,4} min	d ₁ ≈	C _r kN	stat. C _{0r} kN	C _{ur} kN	n _G min ⁻¹
FAG											
F-803477.TR1-J20B	2,64	89,945	146,975	40	3,6	1,5	119	232	355	50	4 800
F-804565.30220-A-J20B	3,7	100	180	37	3	2,5	135	231	290	32	4 300
F-803478.TR1-J20B	9,4	117,475	212,725	63,5	8,1	3,3	162,2	490	720	93	3 000
F-803889.32224-A-J20B	9,15	120	215	61,5	3	2,5	175,2	445	650	84	3 000
F-809028.TR1-J20B	10,2	130	225	67	4	3	174,6	480	710	94	2 800
F-804550.01.TR2S-J20B ¹⁾	6,8	140	190	99	2	1,5	150,1	365	780	74	3 400
Z-577634.01.TR2S-J20B ¹⁾	13,5	140	210	130	2,5	2	175,8	585	1 180	75	2 800
Z-580065.30228-A-J20B	8,6	140	250	45,75	4	3	187	390	520	60	2 600
K36990-36920-J20B	3,18	177,8	227,012	30,162	1,5	1,5	203,8	186	400	30	2 600
F-809055.TR1-J20AA ²⁾	9,34	198,298	282,575	46,038	3,6	3,3	249	345	750	87	2 200
Z-566566.TR1-J20AA	9,28	199,949	282,575	46,038	3,6	3,3	249	345	750	87	2 200
F-807411.TR1-J20B	8,23	240	320	42	3	3	278	380	670	73	2 000
F-809146.TR1-J20AA	18,6	240	336,55	65,088	6,4	3,3	284	640	1 250	137	1 800
F-808428.TR1-J20AA	17,2	240,5	336,55	65,088	6,4	3,3	284	640	1 250	137	1 800
F-808428.TR1-J20B	17,2	240,5	336,55	65,088	6,4	3,3	284	640	1 250	137	1 800
Z-547733.TR1-J20AA	22,3	254	358,775	71,438	3,3	1,5	302,8	720	1 370	148	1 700
Z-547733.02.TR1-J20AA	22,3	254	358,775	71,438	3,3	1,5	302,8	720	1 370	148	1 700

¹⁾ Overall width of matched tapered roller bearings.

¹⁾ Tapered roller-bearing matched in an O-arrangement (spacer between inner and outer rings).

²⁾ Flange at the outer ring.

Hybrid Bearings

As an alternative to coated rolling bearings, FAG offers hybrid bearings that have ceramic rolling elements and rings made from rolling-bearing steel. Hybrid bearings have the suffix HC.

The rolling elements are **absolutely wear-free** and provide the requisite current insulation.

In addition to ball bearings (Fig. 6), we also offer hybrid versions of our cylindrical roller bearings (Fig. 7).

Features and Benefits of Hybrid Bearings

- Greatest resistance to passage of current. Even at higher temperatures, DC-resistance is in the GOhm range. Hybrid bearings typically have a capacitance of about 40 pF, which is lower than for ceramic-coated bearings by a factor of 100.
- Higher speeds with less friction, which translates into lower operating temperatures
- Better dry-running properties

Hybrid bearings have a longer grease life than traditional “lubricated for life” bearings (see TI WL 43-1210).

For small rolling bearing sizes, hybrid designs are more cost-effective than ceramic-coated bearings.

Ordering examples:

HC6214-M-P6-C3 Deep groove ball bearing with ceramic balls; machined brass cage; increased accuracy P6 and bearing clearance C3.

HCN1020-K-M1-SP Cylindrical roller bearing with ceramic rollers; tapered bore; machined brass cage; increased accuracy SP.

Our field-service engineers will be happy to assist you in selecting the most suitable and cost-effective designs for your applications.



6: Deep Groove Ball Bearing with Ceramic Rolling Elements



7: Cylindrical Roller Bearing with Ceramic Rolling Elements

Material Properties for Ceramic Material/Rolling-Bearing Steel

Properties	Unit	Ceramic (silicon nitride Si ₃ N ₄)	Steel (100Cr6)
Resistivity	Ω · mm ² /m	10 ¹⁷	10 ⁻¹
Density	g/cm ³	3,2	7,8
Thermal Expansion			
Coefficient	10 ⁻⁶ /K	3,2	11,5
Modulus of Elasticity	MPa	315 000	210 000
Poisson's Ratio	–	0,26	0,3
Hardness	HV10	1 600...800	700...150

Hybrid Bearings - Table

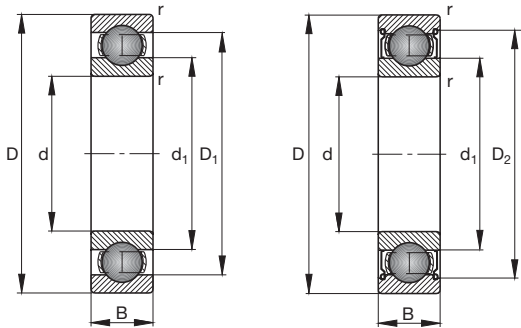

Hybrid Deep Groove Ball Bearings d 15–70 mm

Designation	Mass	Dimensions							Load Rating		Fatigue Limit Load	Limiting Speed	
		m	d	D	B	r	D_1	D_2	d_1	dyn. C_r	stat. C_{0r}	C_{ur}	n_G
FAG	kg	mm								kN	kN	kN	min ⁻¹
HC6002-2Z	0,031	15	32	9	0,3		28,4	20,5	4 150	2 000	102	30 000	
HC6003	0,038	17	35	10	0,3	29,5		22,7	6 000	3 250	157	21 000	
HC6212-C4	0,694	60	110	22	1,5	95,6		76,1	40 500	31 000	1 590	14 000	
HC6014	0,614	70	110	20	1,1	9,3		82,8	29 000	25 500	1 850	10 000	
HC6214-M	1,23	70	125	24	1,5	108		87,1	48 000	39 000	2 050	12 000	

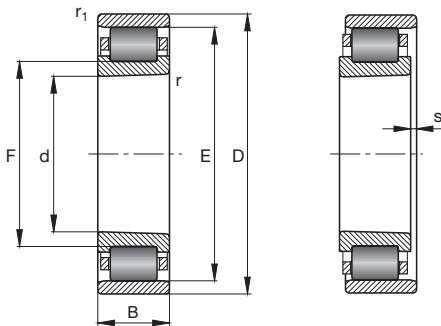

Taper 1:12

Hybrid Cylindrical Roller Bearings d 30–45 mm

Designation	Mass	Dimensions							Load Rating		Fatigue Limit Load	Limiting Speed	
		m	d	D	B	r_1	$s^{1)}$	E	dyn. C_r	stat. C_{0r}	C_{ur}	n_G	
FAG	kg	mm								kN	kN	kN	min ⁻¹
HCN1006-K-M1-SP	0,115	30	55	13	0,6	1,9	48,5	16 000	17 000	2 330	36 000		
HCN1007-K-M1-SP	0,149	35	62	14	0,6	2	55	19 000	20 400	2 700	28 000		
HCN1008-K-M1-SP	0,182	40	68	15	0,6	2,1	61	23 600	27 000	3 700	28 000		

¹⁾ axial displacement

Mounting Examples

1. Three-phase motor

Deep groove ball bearing with a J20AA coating

Technical data:

Three-phase motor, converter-fed

Power 375 kW

Design four-pole

A current-insulated deep groove ball bearing **6316-J20AA-C3** is installed at the ventilation end, and a deep groove ball bearing **6320-C3** is installed at the drive end. Both bearings are lubricated with grease. A relubrication device is provided.

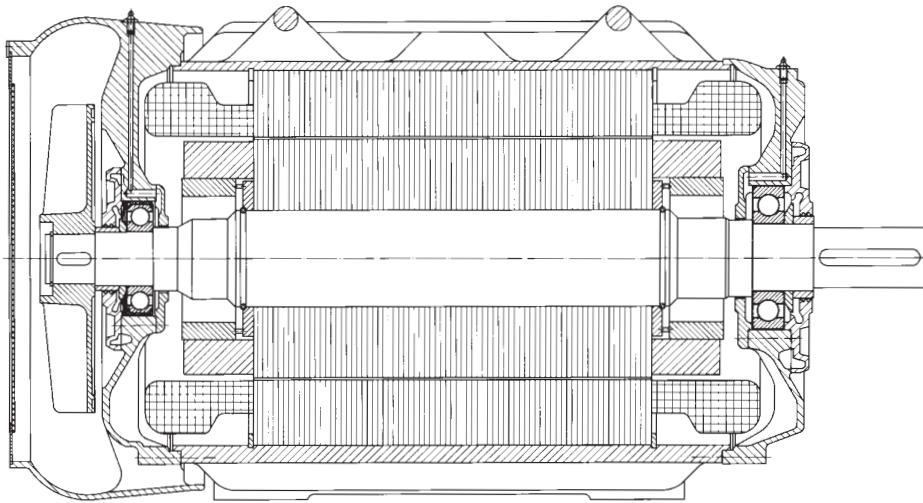

2. Axle box roller bearing

Tapered roller bearings with a J20B coating

Idler mounting in Combino low-floor articulated tramcar, one-meter gauge / Freiburg (Germany)

Technical data:

v_{max} 70 km/h
mean track wheel diameter 560 mm

Tapered roller bearings (O arrangement):
outside **Z-580065.30228-A-J20B**
inside **F-803889.32224-A-J20B**

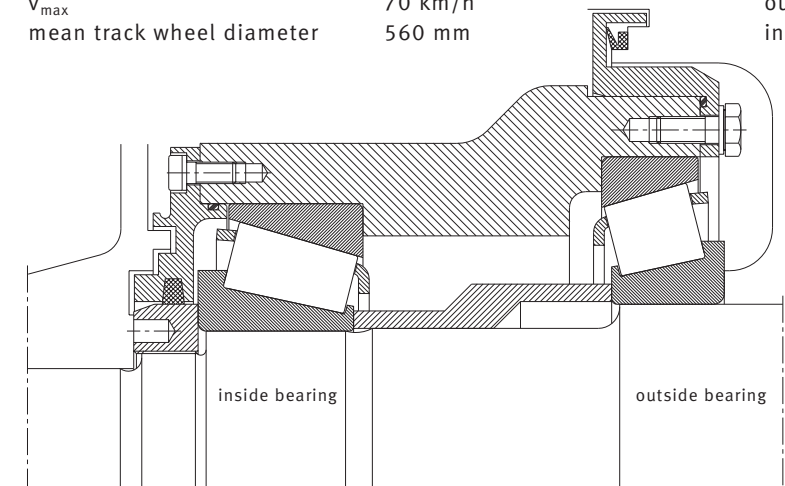

Mounting Examples

3. Traction motor bearing mounting in an electric tramcar

Deep groove ball bearing and cylindrical roller bearing (both with J20AA coating)

500 kW three-phase motor

A deep groove ball bearing **6316-J20AA-C3** is installed at the ventilation end, and a cylindrical roller bearing **NU320-E-M1-F1-J20AA-C4** is installed at the drive end of the rotor shaft.

Both bearings are lubricated with grease and protected from dirt and environmental influences by labyrinth seals.

A relubrication facility was provided.

